

PANEL CUT-OUT

1B METAL CIRCULAR ASSEMBLY P/N DESCRIPTION :

1B A F3 X X XX X 00C
 ①②③④

- ① Insert
 P=PEEK
 1=PPS
- ② Plating
 2=High Gold
 A=Gold flash
- ③ Number of contacts
 02=2Pin
 ...
 16=16Pin
- ④ Keying
 G=0° E=145°
 A=30° F=155°
 B=60° J=45°
 C=90° K=70°
 D=135° L=80°

NOTE:

1. MATERIAL:

1.1.SHELL ASSEMBLY: COPPER ALLOY, OUTER SHELL AND COLLET NUT Cr PLATING,
 OTHER METALLIC COMPONENTS Ni PLATING

1.2.INSERT: THERMOPLASTIC, UL94V-0

1.3.CENTER CONTACT : COPPER ALLOY, Au PLATING

2.NUMBER OF CONTACT : 2 TO 16 POSITION

3.RoHS DIRECTIVE COMPLIANCE

THIRD ANGLE PROJECTION 	TOLERANCES UNLESS OTHERWISE SPECIFIED
UNITS <input checked="" type="checkbox"/> mm <input type="checkbox"/> INCH	0 PLC ± 1.00
ANGLES 0 PLC ± 3	1 PLC ± 0.50
1 PLC ± 2	2 PLC ± 0.25
	3 PLC ±
	4 PLC ±



Dongguan Circon Technology Co.,Ltd.

TITLE: 1B METAL CIRCULAR CONNECTOR
 FIXED SOCKET

APPROVED BY	JACK	DATE	2019-7-18
CHECKED BY	CHARLES	DATE	2019-7-18

C	DRAWING NO.	A-M-097	REV.	AO
	PART NO.	1BAF3XXXXX00C		

REV.	REVISION DESCRIPTION	ECR/ECN NO.	DATE	DRAWN BY	ANDY	DATE	2019-7-18	SIZE: A3	SCALE: 1:1	SHEET: 1 OF 2
------	----------------------	-------------	------	----------	------	------	-----------	----------	------------	---------------

KEYING ANGLES (RECEPTACLE FRONT VIEW):

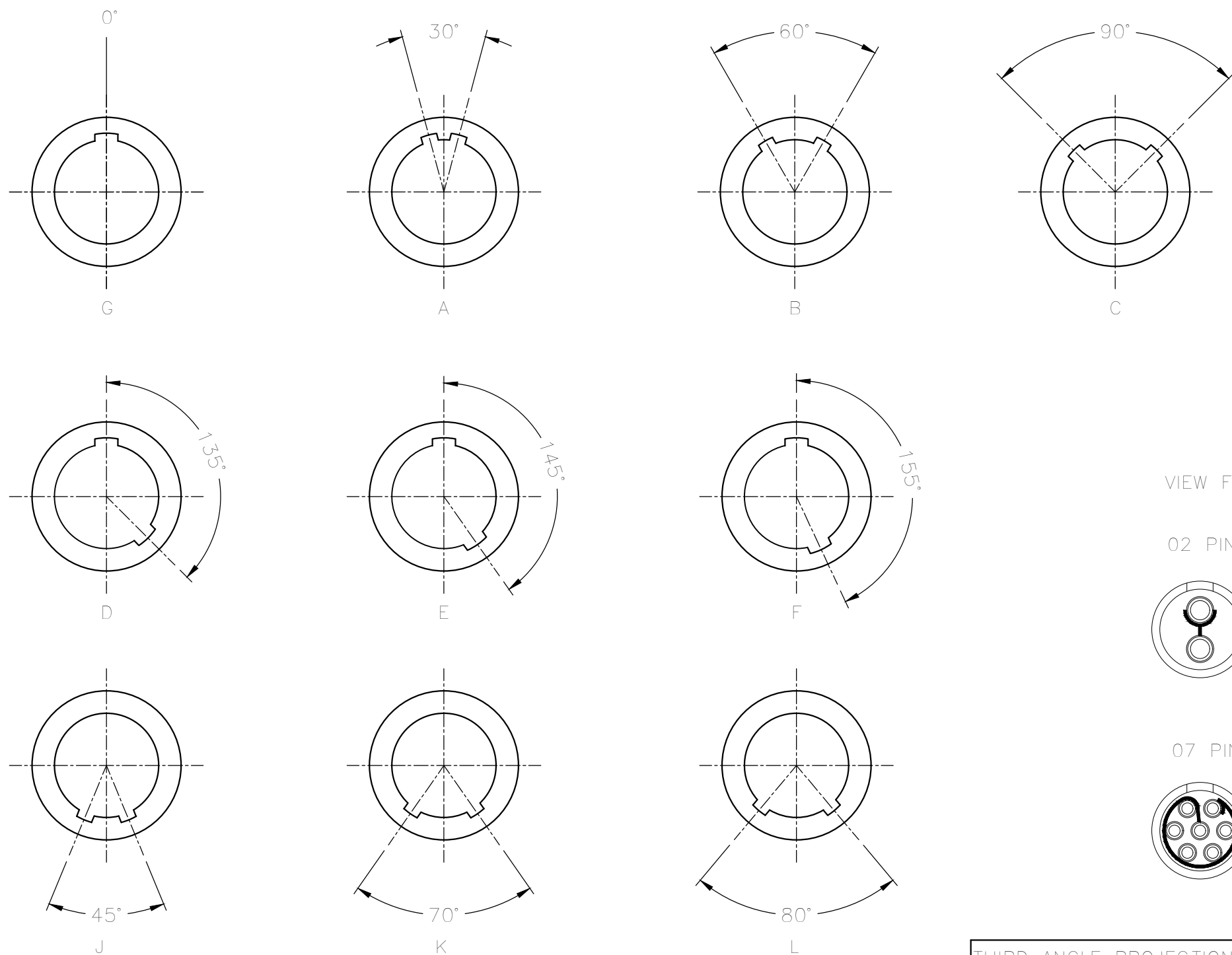

VIEW FROM TERMINATION SIDE PIN PART

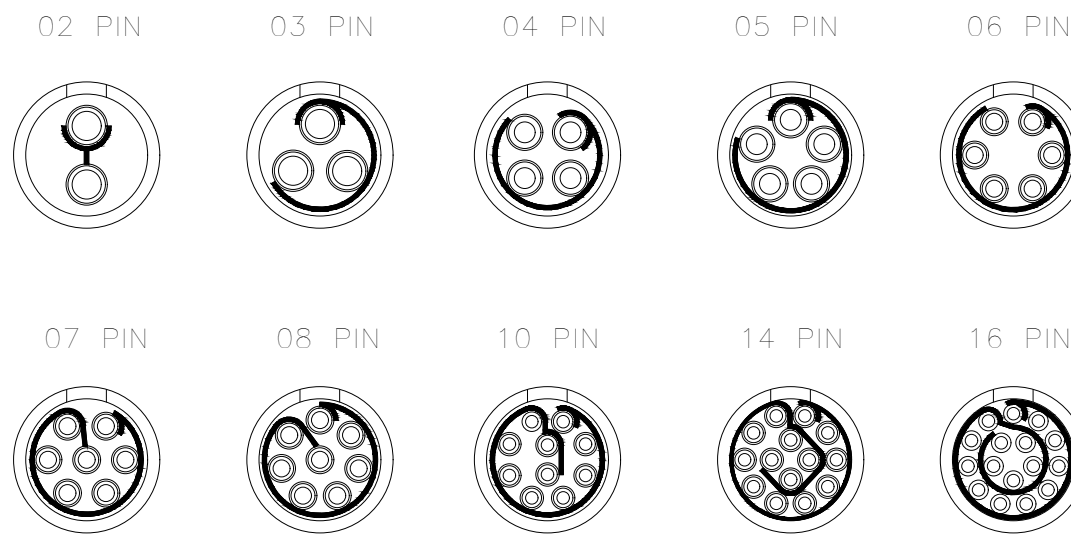

THIRD ANGLE PROJECTION 		TOLERANCES UNLESS OTHERWISE SPECIFIED		 Dongguan Circon Technology Co.,Ltd.	
UNITS <input checked="" type="checkbox"/> mm <input type="checkbox"/> INCH		0 PLC ± 1.00 1 PLC ± 0.50 2 PLC ± 0.25 3 PLC ± 4 PLC ±			
ANGLES 0 PLC ± 3 1 PLC ± 2		APPROVED BY JACK DATE 2019-7-18 CHECKED BY CHARLES DATE 2019-7-18		TITLE: 1B METAL CIRCULAR CONNECTOR FIXED SOCKET	
DRAWN BY ANDY DATE 2019-7-18		C DRAWING NO. A-M-097 PART NO. 1BAF3XXXXX00C		REV. A0	
REV.	REVISION DESCRIPTION	ECR/ECN NO.	DATE	SIZE: A3	SCALE: 1:1